

Continuous Sugar Centrifugal

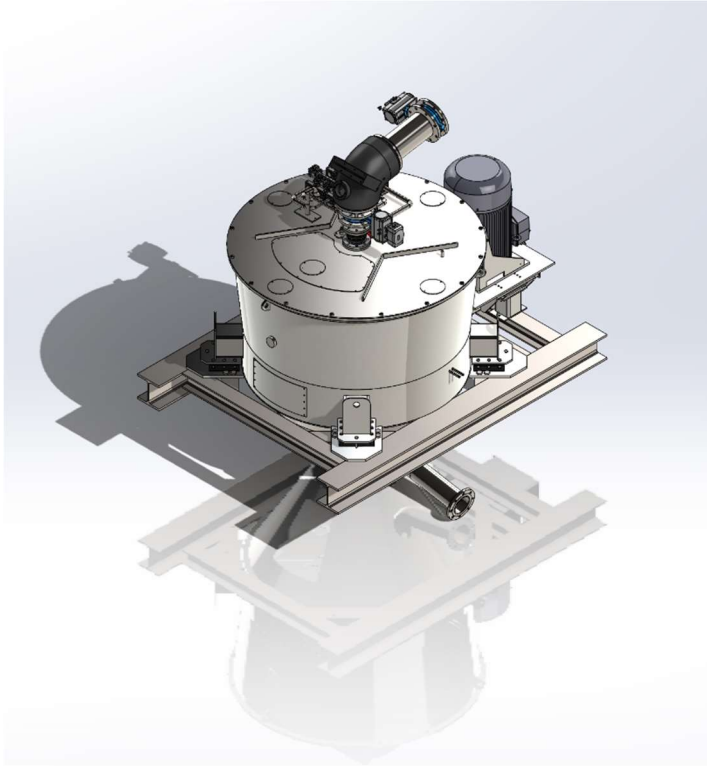

Basket Diameter	: 1300 mm
Basket Angle	: 14°/30°
Motor Power	: 90 kw
Motor Speed	: 1500 rpm
Maximum Basket Speed:	2000 rpm
Dimensions a,b,h	: 2050 mm, 1160 mm 1810 mm
Screen Area	: 1.7 m ²

Proportional butterfly control valve.

Completely closed food safety compatible porridge feeding system.

Basket with two angles for highest sugar recovery.

Corrosion and abrasion resistant duplex material basket.

Advanced bearing system with high strength bearings with long life and high speed range.

Pulleys for power transmission and new V type belts with less friction.

Evenly distributed and regular porridge flow using turbo distributor layers.

Syrup flow guiding fins.

Operator controlled, 3 point water washing and 2 point steam washing line.

High energy efficient motor.

Sensors on motor console for vibration monitoring.

Ergonomic and easy to use case design.